

**Surface Mount and DIP Pressure Sensors Low-Cost Packaged Die**

**DESCRIPTION**

Silicon Microstructures provides its two most popular pressure sensor die in surface mount dual in-line package (SO16) configuration. All parts in these series are uncompensated high-performance die mounted in an injection-molded package designed for surface mounting.

These packaged sensor die provide a way for OEM manufacturers to incorporate pressure sensors at costs close to raw die prices, without the need to handle, attach or wire bond silicon sensor die.

Options include variety of pressure ranges, absolute or gauge pressure types, and a choice of cap configurations. The result is a versatile product line suitable for a wide range of applications.

The low-pressure series (model **SM5470**) incorporates Silicon Microstructure's unique low-pressure die to achieve high performance in pressure ranges from 0.15 PSI to 3.0 PSI full-scale in gauge and differential.

The model **SM5430** comes in gauge, differential, and absolute for pressure ranges from 5 PSI to 60 PSI full scale.

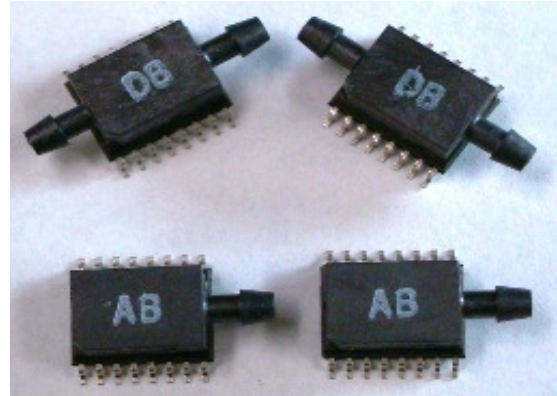

**FEATURES**

- Low pressure (from 0-0.15 to 0-60 PSI Full Scale)
- Easy to Use
- Compact and Light-weight
- High-performance, Stable Silicon Chip and Package
- Easily Embedded in OEM Equipment
- High-volume, Low Cost
- Available in Tape and Reel or IC Sticks

**APPLICATIONS**

- Altimeters
- Barometric Correction
- Tire Gauges
- Digital Pressure Gauges
- Environmental Monitoring
- Appliances
- Consumer and Sports
- HVAC
- Medical Instrumentation and Monitoring
- Pressure Differential and Flow Monitoring
- Hand-held Gauges

**ABSOLUTE MAXIMUM RATING TABLE FOR SM5430/5470 SENSOR**

All parameters measure at 5 V excitation at room temperature, unless otherwise specified.

**All Models**

Parameter	Min.	Typ.	Max.	Units	Notes	
Excitation Voltage	0	5.0	10.0	V		
Excitation Current	0	1.5	3.0	mA		
Zero Offset	SM5470 SM5430	-50 -50	-5 0	+50 +50	mV mV	
TC Span	-15	-19	-24	%FS/100°C	1, 4	
TC Resistance	33	28	25	%/100°C	1, 4	
Bridge Impedance	2.7	3.3	4.0	kΩ		
Operating Temp	-40		85	°C	4	
Storage Temp	-40		85	°C	4	

**SM5430 Standard Pressure Series**

Span (FS Range), PSI (kPa)	Min.	Typ.	Max.	Units	Notes
5 (34)	75	100	125	mV	
15 (103)	105	145	175	mV	
30 (207)	115	165	195	mV	
60 (414)	115	180	220	mV	
Linearity	-0.2	±0.07	+0.2	%FS	3, 4
TC Offset	-5	-1	+5	%FS/100°C	1, 4
Burst Pressure	>5X			Rated FS Pressure	2, 4

**SM5470 Low Pressure Series Only**

Span (FS Range), PSI (kPa)	Min.	Typ.	Max.	Units	Notes
0.15 (1.03)	25	50	85	mV	
0.30 (2.07)	25	50	85	mV	
0.80 (5.52)	25	50	85	mV	
1.50 (10.3)	25	50	85	mV	
3.00 (20.7)	25	50	85	mV	
Linearity	-0.3	±0.1	+0.3	%FS	3, 4
TC Offset	-12		+12	%FS/100°C	1, 4
Burst Pressure	15X			Rated FS Pressure	2, 4

Notes:

1. Measured from 0 to 70°C
2. Sensor die will survive pressure specified for all ranges. Maximum package pressure is 150 PSI.
3. Defined as best-fit straight line (BFSL); for 0.3 PSI full-scale, linearity is ±0.5%FS. For 0.15 PSI full-scale, linearity is ±2.5% Full-Scale.
4. Tested on a sample basis.

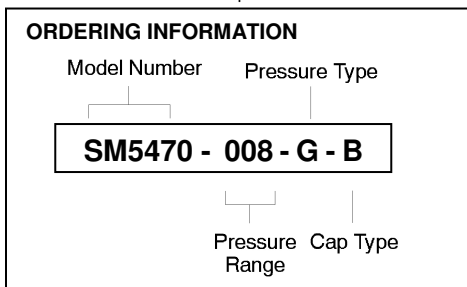

**Pressure Type**

- A: Absolute (except 5470)
- G: Gauge
- D: Differential

**Available Cap Type**

- B: Horizontal Barbed Port(s)

**Std. Pressure Ranges**

PSI	5430
5	005
15	015
30	030
60	060

**Low Pressure Ranges**

PSI	5470
0.15	001
0.30	003
0.80	008
1.50	015
3.00	030

**Pin Out -- SM5430/SM5470**

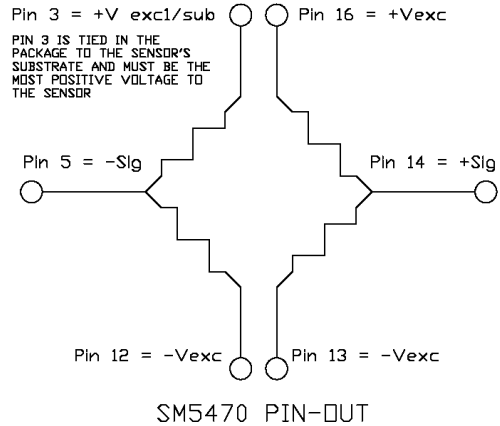
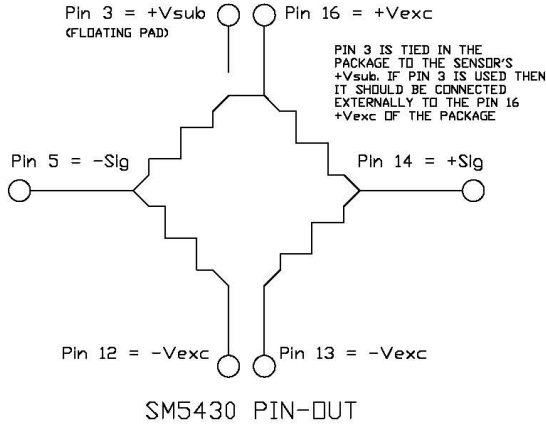

**B- Horizontal Barb Configuration**

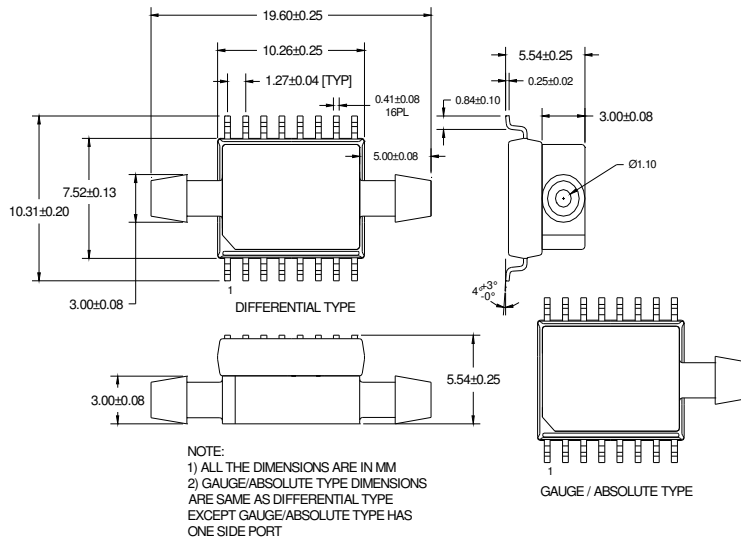

Silicon Microstructures Warranty and Disclaimer:

Silicon Microstructures, Inc. reserves the right to make changes without further notice to any products herein and to amend the contents of this data sheet at any time and at its sole discretion.

Information in this document is provided solely to enable software and system implementers to use Silicon Microstructures, Inc. products and/or services. No express or implied copyright licenses are granted hereunder to design or fabricate any silicon-based microstructures based on the information in this document.

Silicon Microstructures, Inc. makes no warranty, representation, or guarantee regarding the suitability of its products for any particular purpose, nor does Silicon Microstructures, Inc. assume any liability arising out of the application or use of any product or silicon-based microstructure, and specifically disclaims any and all liability, including without limitation consequential or incidental damages. "Typical" parameters which may be provided in Silicon Microstructure's data sheets and/or specifications can and do vary in different applications and actual performance may vary over time. All operating parameters, including "Typicals", must be validated for each customer application by customer's technical experts. Silicon Microstructures, Inc. does not convey any license under its patent rights nor the rights of others. Silicon Microstructures, Inc. makes no representation that the circuits are free of patent infringement. Silicon Microstructures, Inc. products are not designed, intended, or authorized for use as components in systems intended for surgical implant into the body, or other applications intended to support or sustain life, or for any other application in which the failure of the Silicon Microstructures, Inc. product could create a situation where personal injury or death may occur. Should Buyer purchase or use Silicon Microstructures, Inc. products for any such unintended or unauthorized application, Buyer shall indemnify and hold Silicon Microstructures, Inc. and its officers, employees, subsidiaries, affiliates, and distributors harmless against all claims, costs, damages, and expenses, and reasonable attorney fees arising out of, directly or indirectly, any claim of personal injury or death associated with such unintended or unauthorized use, even if such claim alleges that Silicon Microstructures, Inc. was negligent regarding the design or manufacture of the part.

Silicon Microstructures, Inc. warrants goods of its manufacture as being free of defective materials and faulty workmanship. Silicon Microstructures, Inc. standard product warranty applies unless agreed to otherwise by Silicon Microstructures, Inc. in writing; please refer to your order acknowledgement or contact Silicon Microstructures, Inc. directly for specific warranty details. If warranted goods are returned to Silicon Microstructures, Inc. during the period of coverage, Silicon Microstructures, Inc. will repair or replace, at its option, without charge those items it finds defective. The foregoing is buyer's sole remedy and is in lieu of all warranties, expressed or implied, including those of merchantability and fitness for a particular purpose. In no event shall Silicon Microstructures, Inc. be liable for consequential, special, or indirect damages.

While Silicon Microstructures, Inc. provides application assistance personally, through its literature and the Silicon Microstructures, Inc. website, it is up to the customer to determine the suitability of the product for its specific application. The information supplied by Silicon Microstructures, Inc. is believed to be accurate and reliable as of this printing. However, Silicon Microstructures, Inc. assumes no responsibility for its use. Silicon Microstructures, Inc. assumes no responsibility for any inaccuracies and/or errors in this publication and reserves the right to make changes without further notice to any products or specifications herein.

Silicon Microstructures, Inc.<sup>™</sup> and the Silicon Microstructures, Inc. logo are trademarks of Silicon Microstructures, Inc. All other service or product names are the property of their respective owners.

© Silicon Microstructures, Inc. 2001-2011. All rights reserved.